



### **1. Introduction**

As a result of the numerous amounts of technical, economical, environmental and design advantages of LEDs versus conventional light sources, LEDs are located in more and more applications like medical engineering, display technology, automotive, interior and exterior lighting or ambient, mood and general lighting. A number of disadvantages exist, though: Three of them are the dependency of color and efficiency opposed to temperature, aging and forward current. The heat generation of LEDs in contrast to other light sources is relatively small. However, the temperature range of the application has to be considered. LED systems have to cope with more or less expanded ranges, for example 0°C to 50°C in backlight systems or general in lighting devices. The heat removal is to be done by means of cooling with heat sinks or fans, but they can avoid the warming of LEDs only with high effort. This is similar to the additional use of active cooling elements which cause, in turn, a higher consumption. Not only temperature, also aging and forward current are responsible for the color shift. Brightness can vary up to 20% between LEDs even out of the same charge. Furthermore, the distribution of the dominant wavelength for LEDs of the same type is about  $\pm 8\text{nm}$ , after classification in wavelength groups  $\pm 3\text{nm}$ .

In sum the named factors cause differences for multicolor LEDs visible with the human eye, which can be compensated with color sensors.

### **2. Functionality of color sensors**

The most conventional sensor technology for color sensors is the tristimulus method based on RGB or other spectral filters which are implemented as interference or absorption filters. Color sensors of MAZeT are based on high-quality interference and XYZ spectral filters which defines that the output values of the detector emulate the tristimulus value function of the human eye (Values are defined in the CIE 1931 color space).

After being amplified and digitalized, the three detector signals approximate the tristimulus values XYZ. Compared to spectrometers, color sensors present a cost-effective solution for the measurement and control of illumination. They can be designed with absorption or interference filter in front of a light sensitive detector. Some main characteristics of the several filter types are listed in Table 1 and 2.

## Improved LED systems with true color sensors

Characteristic	Absorption filter	Interference filter
Maximum transmission in the transmission range	Typical Range 60...70%	> 95%
Remaining transmission in the cut-off region	Typical Range 10...20%	< 1%
Temperature stability	Dependant on filter material	Independent from temperature – high temperature stable
Transmission characteristic	Aging due to absorption	Long-term stability without drifts

Table 1: Comparison of absorptions and interference filter

Filter	RGB	XYZ (True Color)
peak/position/sensitivity	equally shared in VIS based on used filter material	tri-stimulus function - standard observer function (CIE 1931, DIN5033)
interface	red, green blue part of incoming – any status	xyY, Lab, Luv coordinate in color space
applicable for	color teaching and detection	absolute or relative color measurement with an accuracy of $\Delta E < 3$ and/or $\Delta u'v' < 0,002$ (like human eye)

Table 2: Comparison of RGB and XYZ filter

The MAZeT XYZ sensor IC MTCSiCS is worldwide the unique color sensor which realizes the tristimulus value function using a combination of photodiode and interference filter. In consequence, the three output voltages of the MTCSiCS present XYZ based values. A comparison of the three resulted filter functions  $x_{\text{MTCSiCS}}(\lambda)$ ,  $y_{\text{MTCSiCS}}(\lambda)$ ,  $z_{\text{MTCSiCS}}(\lambda)$  and of a typical RGB color sensor<sup>1</sup>  $r(\lambda)$ ,  $g(\lambda)$ ,  $b(\lambda)$  is shown in Figure 1.

<sup>1</sup> e.g. different alternatives on the market

## Improved LED systems with true color sensors

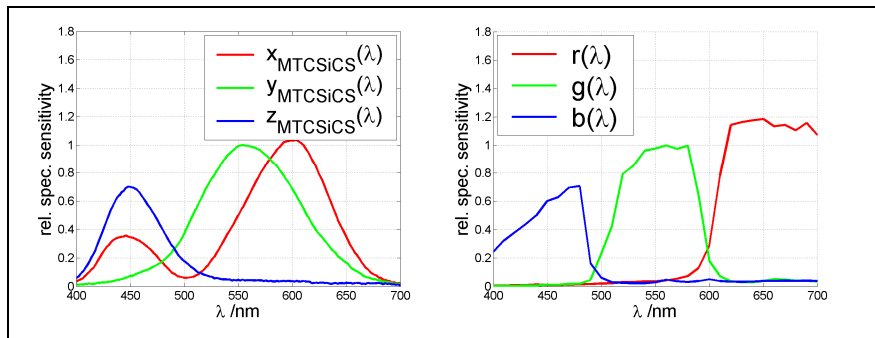


Figure 1: Filter functions of true (left) and RGB (right) color sensor

Incident light, for example from a multicolor LED (RGB LED), causes a photo current depending on the illuminance of the light source. The following electrical amplification converts the current into voltage which is digitalized for calibration and signal processing. The software is realized in a microcontroller and/or PC (Figure 2).

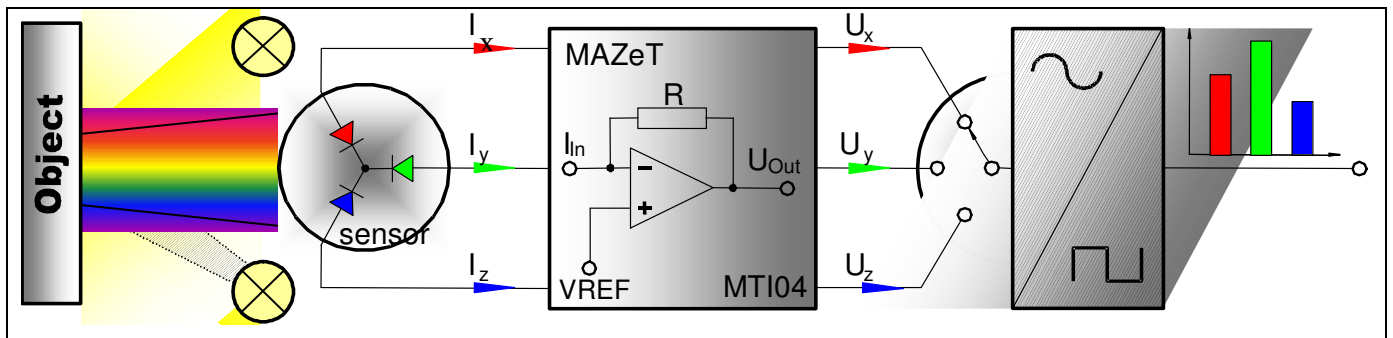


Figure 2: The way from light to XYZ

The resultant XYZ tristimulus values can be computed in other color spaces, for example  $Y_{xy}$  or  $L^*u^*v^*$  CIE 1976, where  $Y$  and  $L^*$  are measures for the brightness and  $xy$  and  $u^*v^*$  for the chromaticity coordinate. These two color spaces are usually used for self-illuminating targets. Depending on the coloring, the human eye can differ between two colors down to a color difference of  $\Delta u^*v^* = 0,005$  (for average eyes, trained ones see as different until 0,003) and a brightness of 4%. These values are mainly criteria for the quality and success of color control for RGB LEDs. The following text consults the color space  $L^*u^*v^*$ .

The reference value  $L^*u^*v^*(r)$  for a color control can be set manual or measured by a second color sensor focused on another LED or display to reproduce it. The actual color of the LED is measured with a color sensor in XYZ and computed to  $L^*u^*v^*(a)$ . According to the difference  $L^*u^*v^*(r) - L^*u^*v^*(a)$ , a proportional controller sets the new PWM duty cycles for the red, green and blue LED until  $L^*u^*v^*(r)$  is reached.

## Improved LED systems with true color sensors

---

The different color gamut of multicolor LEDs must be subject of particular consideration. Reference values could not be reached if several multicolor LEDs are controlled with a reference value, chosen in border areas of the gamut. In this case, a smaller gamut should be selected.

A possibility other than color sensors is the control by measuring the junction temperature. This method, however, requires the knowledge of the exact behavior of the temperature. Therefore, the luminous flux over temperature must be determined for each LED to compensate the temperature effect during operation mode. Furthermore, aging must be compensated by measuring each LED at a defined temperature and adjust the difference to a reference value. Another disadvantage is the sole use of pulse width modulation controlled LEDs, due to the additional shift of the dominant wavelength according to the forward current, which cannot be controlled by measuring the junction temperature.

The next table lists some alternatives of color control:

Measurement	Advantages	Disadvantages
None	<ul style="list-style-type: none"> <li>▶ Low cost</li> </ul>	<ul style="list-style-type: none"> <li>▶ Non constant color point over temperature and aging effects</li> </ul>
Temperature	<ul style="list-style-type: none"> <li>▶ Only one simple thermal sensor</li> <li>▶ Calculating based on a-priori knowledge of wavelength shift and degreasing of intensity</li> </ul>	<ul style="list-style-type: none"> <li>▶ No optical measurement</li> <li>▶ Measurement of parasitic parameter</li> <li>▶ No detection of aging effects and damage effects</li> <li>▶ Hysteresis of temperature coupling</li> </ul>
Intensity	<ul style="list-style-type: none"> <li>▶ Only on simple optical sensor</li> <li>▶ Calculating based on a-priori knowledge of depending of degreasing of intensity and wavelength shift</li> </ul>	<ul style="list-style-type: none"> <li>▶ Optical measurement</li> <li>▶ No color measurement</li> <li>▶ No detection of aging effects and damage effects</li> </ul>
RGB color	<ul style="list-style-type: none"> <li>▶ measurement of mixed color effects</li> <li>▶ Measurement of RGB effects and Intensity of RGB values</li> </ul>	<ul style="list-style-type: none"> <li>▶ No real color measurement</li> <li>▶ Worse interpretation of color point</li> <li>▶ two additional sensing channels</li> </ul>

## Improved LED systems with true color sensors

Measurement	Advantages	Disadvantages
XYZ color	<ul style="list-style-type: none"> <li>▶ Real measurement of mixed color</li> <li>▶ Measurement of real color coordinates and brightness</li> </ul>	<ul style="list-style-type: none"> <li>▶ two additional sensing channels</li> </ul>

Table 3: Measuring methods of color control

### 3. Calibration

According to the tristimulus method, color sensors are calibrated with the following formula:

$K = (XYZ \cdot X_s Y_s Z_s^T) \cdot (X_s Y_s Z_s \cdot X_s Y_s Z_s^T)^{-1}$
K: 3x3 correction matrix XYZ: 3x4 target data X <sub>s</sub> Y <sub>s</sub> Z <sub>s</sub> : 3x4 sensor data T: Transpose of matrix -1: Inverse of matrix

Because of the linear dependency of the basic colors of the used LEDs - in most cases red, green and blue - and their mixed color, it is theoretically sufficient to calibrate the sensor with red, green and blue. However, it is practicable to add white (red, green and blue driven at 100%) in order to reach better results for gray-scale colors. The four colors are measured with color sensor and spectrometer at the same time, while the sensor is placed at its well-defined position in the LED system. Sensor and spectrometer (target) data are inserted in the above-mentioned formula to compute a 3x3 correction matrix. This procedure is to be done for each color sensor. Later on, the measured sensor values are multiplied with the corresponding correction matrix to get XYZ tristimulus values.

Due to the long-term stability of the used interference filters (Table 1), the MAZeT MTCSiCS true color sensors have to be calibrated only on time and then never if the conditions in work are not changing.

### 4. Color sensors in LED systems

An example based on the MTCSiCS true color sensor and RGB LEDs is consulted to describe how to install a color sensor in an LED system.

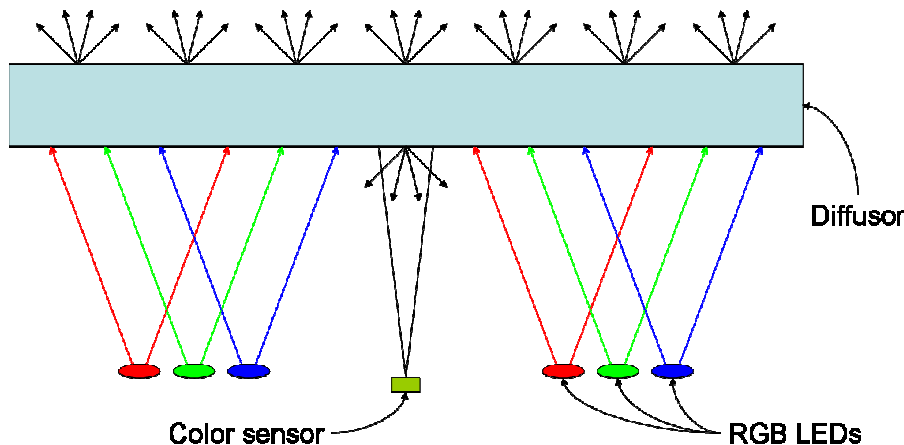


Figure 3: Color sensor placed in a LED system

Depending on the system, different requirements are made. In general, the following basic requirements must be fulfilled:

**Requirement 1:** Color sensor focused on a homogeneous surface.

**Reason:** Stray light or direct light of one LED causes a measuring error.

**Solution:** For a sufficient mixing of LED light, a basic lighting device is chosen where the RGB LEDs and the color sensor are installed behind a diffuser (Figure 3). Other designs are possible, of course - for instance placing the sensor and/or the LEDs sidwise of the diffuser or to lead through the LED light with an optical waveguide on the sensor surface.

**Requirement 2:** Fast electrical small signal amplification.

**Reason:** The generated photo current is in the range of nano-/microampere. In addition, many LED systems are used in applications, where the desired, controlled color must be available in a few milliseconds.

**Solution:** One possibility is the transimpedance amplifier MTI04 of MAZeT GmbH. This current-voltage converter is specially designed for small currents. It furthermore features eight amplification stages to adapt the amplification to the illuminance (see requirement 3) for a high dynamic range.

## Improved LED systems with true color sensors

---

**Requirement 3:** Adjustment of the digitalized values to the operating temperature range.

**Reason:** The relative light output of long wave (red) LEDs can decrease up to 40% during a temperature rise from 0°C to 50°C. Because of the linear dependency of illumination and photo current, the digitalized values will decrease/increase at the same amount. To avoid over amplifying of the sensor when the LED is cooled, the digitalized values must be fit to the operating temperature range for the LED system.

**Solution:** For low-cost systems or a limited temperature range, it is effectual to adjust the digitalized sensor values to 50% - 70% when all LEDs are set to maximum power at medium ambient temperature. For example 60% at 25°C will provide about 80% at 50°C. For expanded temperature ranges or systems with a high performance concerning the brightness modulation, the above-named MTI04 offers the possibility to set the required amplification for adjusting the digitalized values to the actual needs.

According to the actual state of technology, LEDs are driven via pulse width modulation (PWM) with a constant current or are controlled by forward current. A disadvantage of current controlled LED drivers is the additional shift of wavelength depending on a change of the forward current. This causes a second variation of the chromaticity coordinate in addition to the variation due to the temperature. The MTCSiCS in combination with the MTI04 can operate with both types of LED drivers. So, the above-mentioned disadvantage of current controlled LED drivers is compensated without any extra efforts in hardware or software.

This fact provides an opportunity for LED systems with high requirements concerning dynamic behavior: To control the desired color via PWM and the brightness via current control. The advantage is a higher PWM resolution for low brightness colors, where the human eye is more sensitive against color changes.

### 5. Improvement of color stability

To demonstrate the compensation of color drift caused by temperature variation with color sensors, a LED system with the MTCS-C2 Colorimeter Board (Figure 1) is realized. This board consists of an MTCSiCS true color sensor, an MTI04 transimpedance amplifier and a microcontroller to send the 10-bit digitalized sensor values via USB to a PC. For the test, a MTCS-C2 is modified by replacing the MTCSiCS with a RGB color sensor.

## Improved LED systems with true color sensors

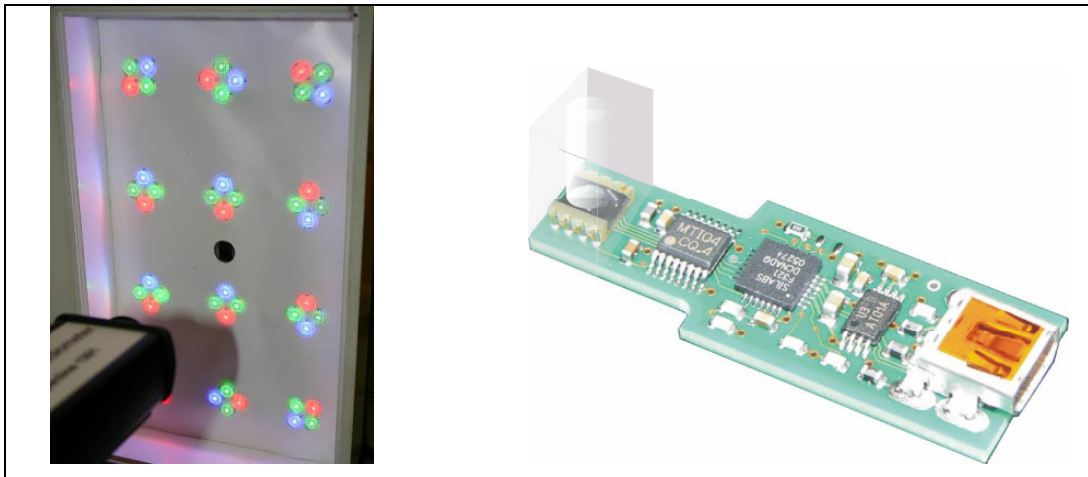



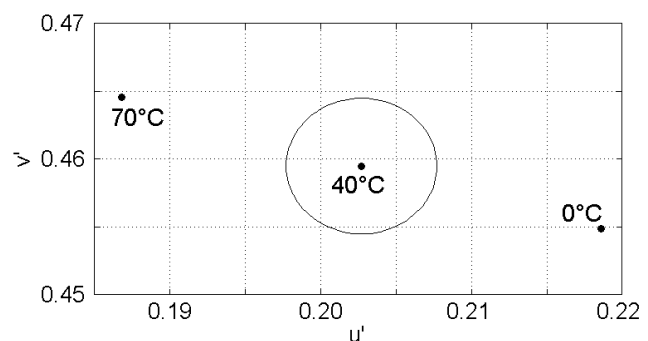


Figure 4: MTCS-C2 Colorimeter Board (right) / example for backlight demonstrator (left) with a measurement position for the true color sensor in the middle of the panel (diffuser for picture removed).

A RGB Power LED (peak wavelengths 465nm - 530nm - 625nm), driven with 8-bit PWM and 250mA, is placed behind a diffuser, which homogenizes the LED light. The MTCS-C2 and a spectrometer - for an accurate measurement of the color chromaticity and brightness - are positioned in front of the diffuser. Both sensors are calibrated - as explained in section 3 - at a heat sink temperature of 40°C. During the test, heat sink temperature is cooled down to 0°C and heated to 70°C in three runs. The first one without any control, the second is controlled by the MTCS-C2 with RGB color sensor and the third run is controlled by the MTCS-C2 with an MTCSiCS true color sensor. As reference color, the duty cycle of PWM for red, green and blue is set to 70% at 25°C. The following tables show the results measured with the spectrometer:

### Run 1: without control



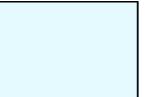
	0°C	40°C	70°C
<b>L*</b>	132,7	125,4	122,6
<b>u'</b>	0,2186	0,2027	0,1868
<b>v'</b>	0,4549	0,4595	0,4646
<b>RGB color</b>			
	<b>Δ0°C - 70°C</b>		
<b>ΔL*</b>	-7,5%		
<b>Δu'v'</b>	0,0332		

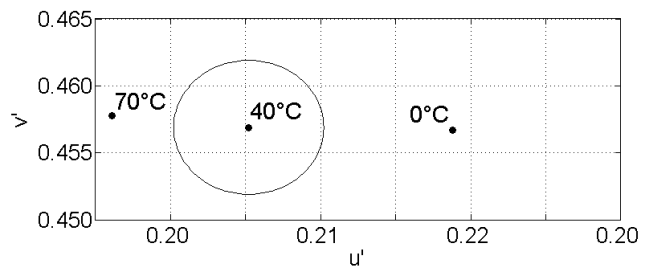


**Diagram:**  
Shift of the chromaticity coordinate  $u'v'$  caused by temperature. The circle indicates the  $\Delta u'v' = 0,005$  range not visible for the human eye.

## Improved LED systems with true color sensors




### Run 2: control with RGB color sensor

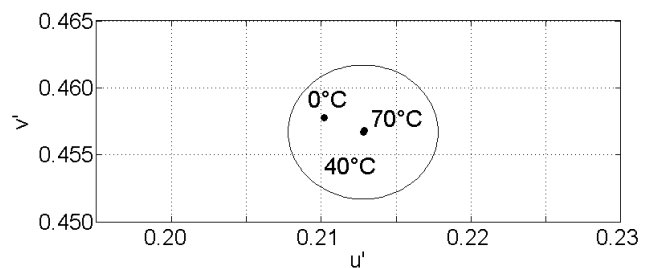
	0 °C	40 °C	70 °C
<b>L*</b>	130,2	127,7	128,9
<b>u'</b>	0,2188	0,2052	0,1961
<b>v'</b>	0,4567	0,4569	0,4578
<b>RGB color</b>			
<b>Δ0 °C - 70 °C</b>			
<b>ΔL*</b>	-1,0%		
<b>Δu'v'</b>	0,0227		



*Diagram:*  
Shift of the chromaticity coordinate  $u'v'$  caused by temperature. The circle indicates the  $\Delta u'v' = 0,005$  range not visible for the human eye.

### Run 3: control with MTCSiCS true color sensor

	0 °C	40 °C	70 °C
<b>L*</b>	129,0	128,6	129,4
<b>u'</b>	0,2102	0,2128	0,2129
<b>v'</b>	0,4578	0,4567	0,4568
<b>RGB color</b>			
<b>Δ0 °C - 70 °C</b>			
<b>ΔL*</b>	0,3%		
<b>Δu'v'</b>	0,0028		



*Diagram:*  
Shift of the chromaticity coordinate  $u'v'$  caused by temperature. The circle indicates the  $\Delta u'v' = 0,005$  range not visible for the human eye.

*Notice:* The RGB-colors are computed out of the corresponding chromaticity coordinate  $u'v'$ , while the brightness  $L^*$  is scaled to 1. Due to different color gamut of displays or print media, the RGB-colors can appear inaccurate. However, the shift of chromaticity coordinates between uncontrolled, controlled ones with an RGB color sensor and controlled ones with an MTCSiCS true color sensor is obvious.

### 6. Summary

Due to the shift of the chromaticity coordinate and brightness in dependency to temperature, aging and forward current, a control of multicolor LEDs is necessary in applications where homogenous and constant light must be created. A control by measuring the junction temperature requires the exact knowledge of the LED characteristics. It was shown that uncontrolled LED systems produce unacceptable color differences over a temperature range of 70K. In systems controlled with RGB color sensors, the differences are reduced, but are still about a factor 4 above  $\Delta u'v' = 0,005$ . Only the use of true color sensors leads to success and provides results not visible to the human eye.

#### Author:

Name: Dipl.-Ing. (FH) Fredrik Hailer  
Studies: Mechatronics (University of Applied Sciences Karlsruhe)  
Employer: MAZeT GmbH (Jena) since April 2007  
Job title: Field Application Engineer Optoelectronics  
Specific field: Color and Spectral sensor technology